

(LM-ZMD-M)

# Operating instructions

Revised in 2021

# Chapter 1 technical conditions

## 一、Function overview

Lm-zmd combined adsorption dryer control box adopts integrated four line LCD + PLC automatic control, adopts international standard Modbus communication protocol, all sensors are connected with the bus, which is more reliable and simple than distributed connection; Chinese interface; can be connected with PC through RS485 interface for parameter setting, data acquisition and monitoring.

The whole machine has advanced technology, reliable performance, complete functions, beautiful appearance, more convenient operation, installation and maintenance, and adopts independent power processing module, which makes the overall performance of the machine more reliable.

## 二、Technical index

- (1) NTC temperature measurement:  $-30 \sim +150$  °C, accuracy of  $\pm 1$  °C
- (2) Power input: DC voltage  $24V \pm 5\%$ .
- (3) Power consumption: 24W.
- (4) Switch output: 8-point relay contact, voltage AC220 V or DC24 V, inductive current load 0.8A; Resistive load: 2A
- (5) Switch input: 8-point input, V - is public input.
- (6) Analog quantity: 2-way output (0-10V = 0-4095); 2-way input (0-20mA = 0-4095); 4-way NTC
- (7) Working environment: temperature  $0 \sim 50$  °C, humidity no more than 85%, vibration no more than 0.5g. There is no obvious dust, acid, corrosive gas or substance in the surrounding air.
- (8) Communication: RS485 interface, half duplex mode, MODBUS-RTU communication protocol, effective distance  $\leq 1200m$

## 三、Appearance: unit mm

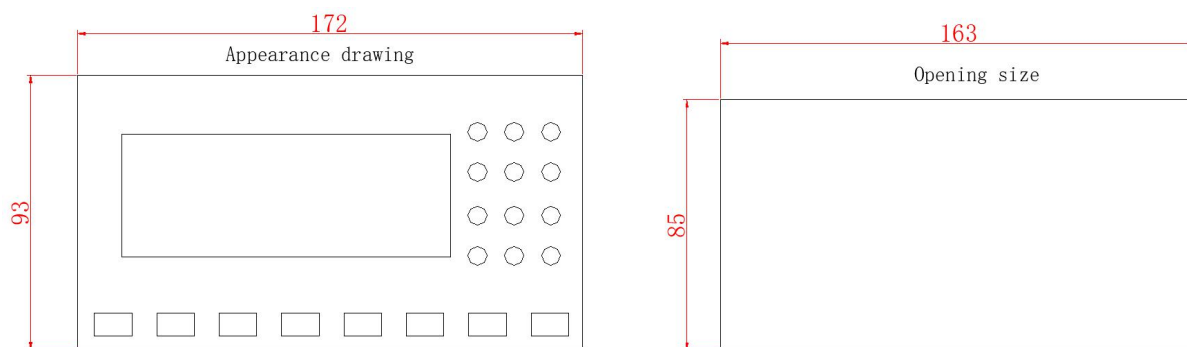

#### 四、Abbreviations

The abbreviations used in this system are as follows

Serial number	chinese	abbreviation	english
1	进气温度	IAT	Intake Air Temperature
2	出气温度	OGT	Outlet Gas Temperature
3	露点温度	DPT	Dew Point Temperature
4	蒸发温度	ET	Evaporation temperature
5	加热温度	HT	heating temperature
6	冷冻温度	FT	Freezing temperature
7	冷凝温度	CT	Condensing Temperature
8	湿度值	HV	Humidity value
9	再生	REG	Regenerate
10	节能	ES	energy-saving
11	上限	UL	Upper Limit
12	下限	LL	lower limit
13	补偿	COMP	Compensation
14	保护	PROT	Protection
16	压缩机	CP	Compressor
17	压力控制开关	POS	Pressure Operated Switch
18	相序	PS	Phase sequence
19	冷媒	RF	Refrigerant
20	报警	ALM	alarm
21	可变压力	VP	Variable Pressure

## Chapter 2 Operation and maintenance

### 一、LCD panel key menu



Key	basic function
[ESC]	No matter the display is in any picture, once you press this key, you will return to the main picture of the system. When there is an alarm, press ESC key three times to confirm the alarm. When it cannot be reset, the alarm still exists.
[ALM]	Press this key to return to the system and automatically switch to the defined alarm information screen
[←]	OFF Key
[→]	ON Key (Alternate startup of A / B tower)
[↑]	Flip the screen to the front page, If in the data setting state, increment the modified digit bit by 1, increasing the range: :0—>9—>0
[↓]	Flip the screen to the next page, If in the data setting state, the modified digit bit is reduced by 1, decreasing the range: 9—>0—>9
[SET]	Press this key to start modifying the register value. The register window being modified is displayed in reverse color, and the modified number of digits flashes. If the current screen does not have a register setting window component, a null operation is performed. Pressing the [SET] key once more before pressing the [ENT] key cancels the current modification operation and proceeds to the next data register.
[ENT]	When the user uses the encryption function, press this button to pop up the password setting screen. In the register setting state, the modified data is written to the register, and the next data register is modified. After the last register of the current screen is modified, exit to modify the register state.
[CLR]	When setting the register value, press this key to clear the value to zero, directly press the number key to enter parameters, press ENT key to confirm.

## 二、 Welcome screen

In the work screen, press the [↑] key, Switch this screen

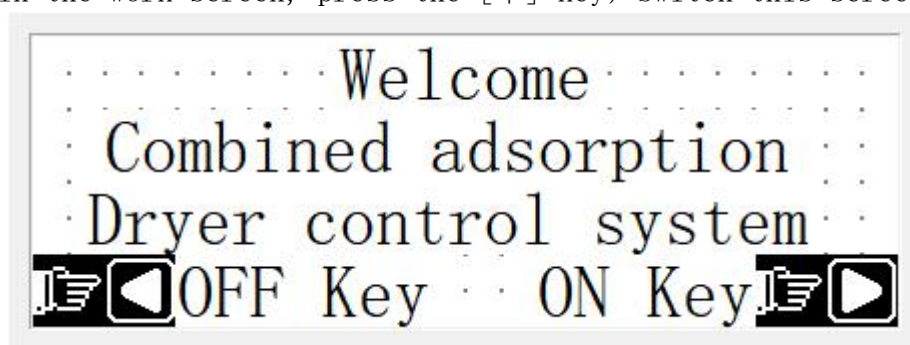

## 三、 Startup screen (main screen)

Users connect the line, check without error, before power on, power on the screen is shown as follows:

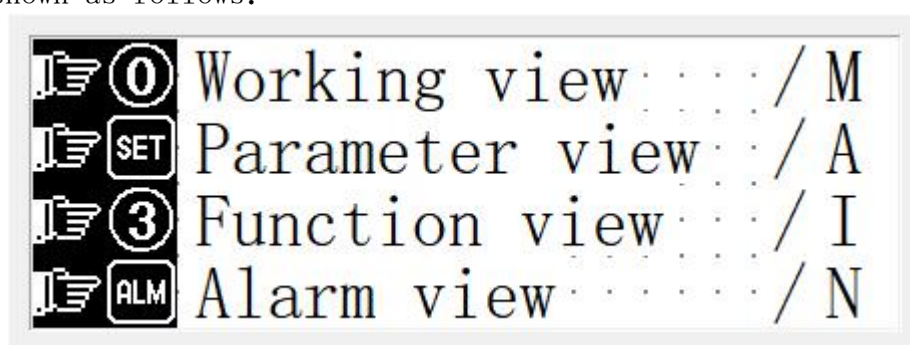

Key	Functions and permissions	purpose
[0]	Shortcut key (no permission)	Switch to the working screen (only this screen is valid)
[SET]	Shortcut key (no permission)	Switch to the parameter setting screen
[ALM]	Shortcut key (no permission)	Switch to alarm screen
[3]	Shortcut key (with permission) (1234)	Switch to function parameter screen (only this screen is valid)

## 三、 Working view

Press the 【↓】 button in the main screen, Switch this screen

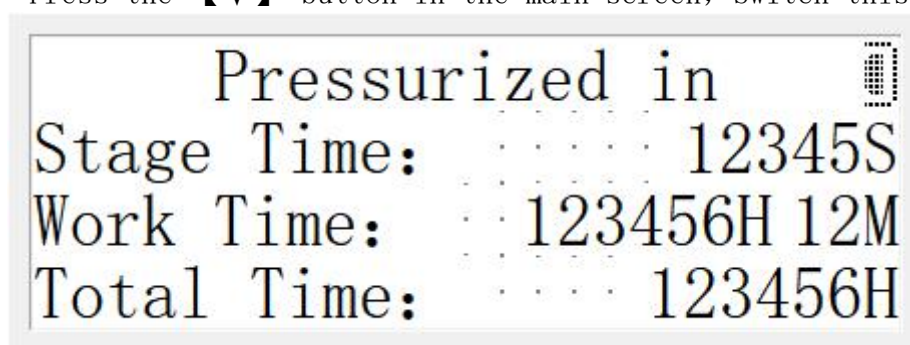

Key	Functions and permissions	purpose
[←]	Shortcut key (no permission)	OFF Key
[→]	Shortcut key (no permission)	ON Key (Alternate startup of A / B tower)
【0】	Shortcut key (no permission)	A tower start button (only this screen is valid)
【1】	Shortcut key (no permission)	B tower start button (only this screen is valid)
【2】	Shortcut key (no permission)	OFF Key (only this screen is valid)

Note: alternate start-up of tower AB refers to the start-up of tower a or Tower B after the completion of regeneration. For example, when tower a is to be regenerated, hot regeneration (Once regeneration) or cold regeneration (Twice regeneration) is shut down, it is still tower a working; when it is shut down in the charging stage, it is switched to another tower working

#### 四、Temperature display screen

In the work screen, press [↓], Switch this screen

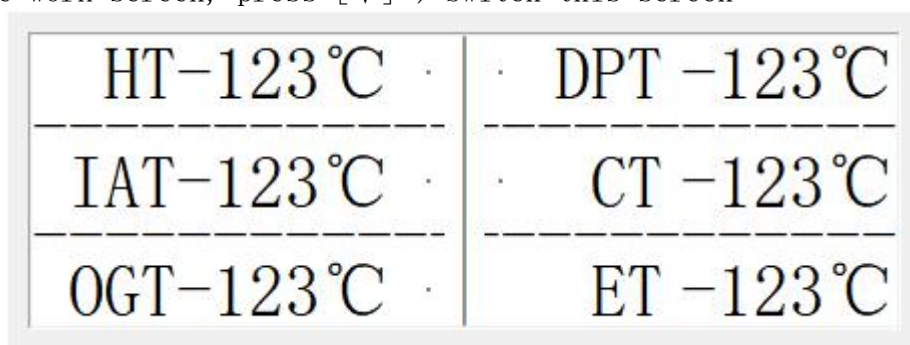

#### 五、Mode screen

In the temperature display screen, press [↓], Switch this screen

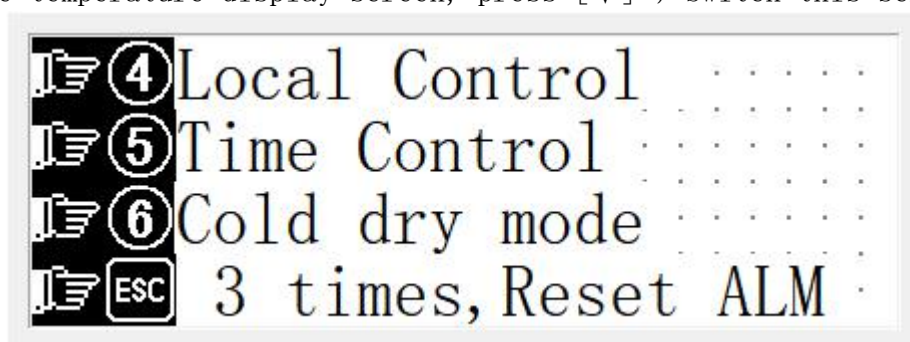

Key	Functions and permissions	purpose
【4】	Shortcut key (no permission)	Switch local / remote control (only this screen is valid)
【5】	Shortcut key (no permission)	Switching Time / DPT control (only this screen is valid)
【6】	Shortcut key (no permission)	Cold drying mode: the cold dryer system works independently Drying mode: the dryer system works independently Linkage mode: cold dryer and suction dryer work at the same time When the device is running, the mode switch is invalid (only this screen is valid)

#### 六、Parameter setting screen

Press [set] on the main screen, Switch this screen

Parameter setting 1: Micro Hot Work

Delay RGE T1: . . . . .	1234 S
Heating T2: . . . . .	1234 M
Blowing Cold T3: . . . . .	1234 M
Pressurized T4: . . . . .	1234 M

Parameter setting 1: No Hot Work

Delay RGE T1: . . . . .	1234 S
Once REG T2: . . . . .	1234 S
Twice REG T3: . . . . .	1234 S
Pressurized T4: . . . . .	1234 S

Parameter setting 2:

AB Work T5: . . . . .	1234 S
Stop Pressurize: . . . . .	1234 S
Start Delay: . . . . .	1234 S
Stop Delay: . . . . .	1234 S

Parameter setting 3:

ET ALM Delay . . . . .	1234 M
DPT ALM Delay . . . . .	1234 M
DPT ES Time T6 . . . . .	1234 M
DPT High ALM . . . . .	-1234°C

Parameter setting 4:

DPT ES . . . . .	-1234°C
CT High ALM . . . . .	-1234°C
ET High ALM . . . . .	-1234°C
IAT High ALM . . . . .	-1234°C

Parameter setting 5:

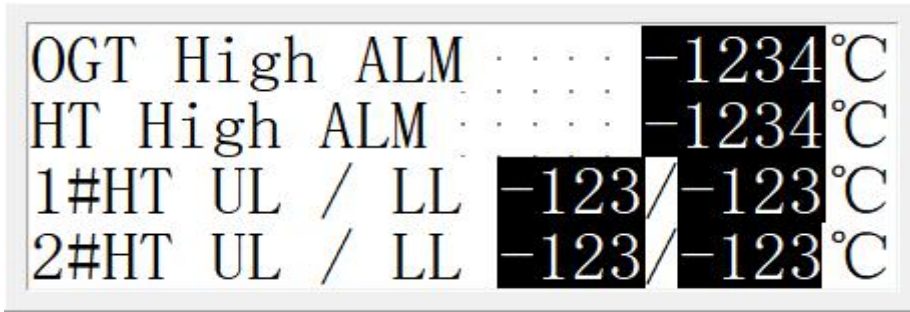

Parameter setting 6:

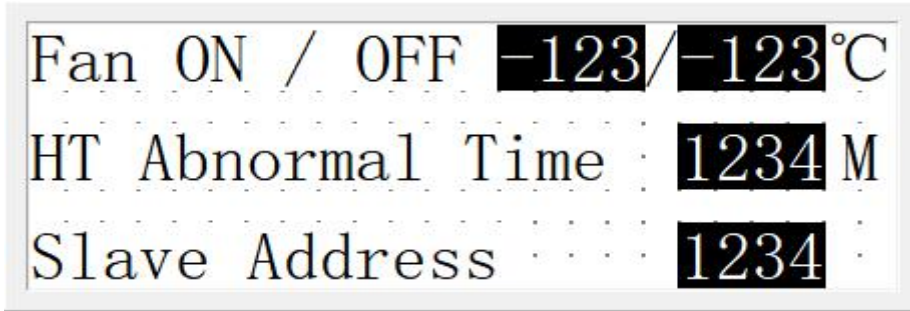

Parameter setting 7:

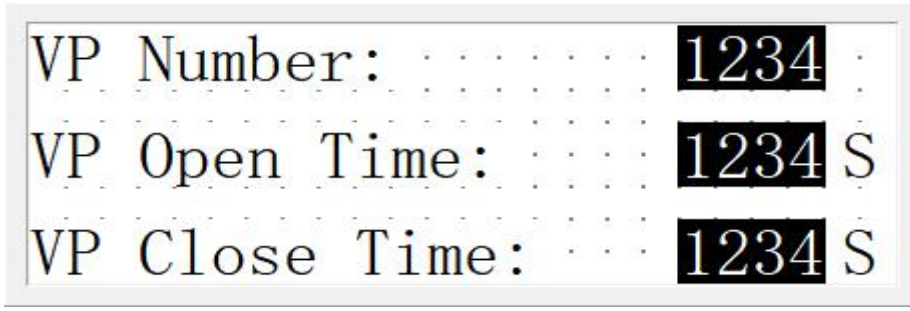

Users can adjust the corresponding parameters according to the work needs.

Micro Hot Work	Time control: $T1+T2+T3+T4+T5$ =Half cycle time DPT control: $T1+T2+T3+T4+T5+T6$ =Half cycle time
No Hot Work	Difference: $T2 + T3$ = regeneration time

Tips: 1. When the dew point energy saving time 、 abnormal heating time 、 Variable Pressure Number are set to 0, their functions are shielded

2. Humidity compensation = dew point compensation

3. Introduction to pressure transformation: during the regeneration time, the regeneration valve passes the "VP Number", and the regeneration valve opens the "VP Open Timee" , Regeneration valve closing "VP Close Time"

Pressurized T4、 DPT ES Time T6、 DPT ES、 Time Control、 DPT Control

Relationship logic diagram:

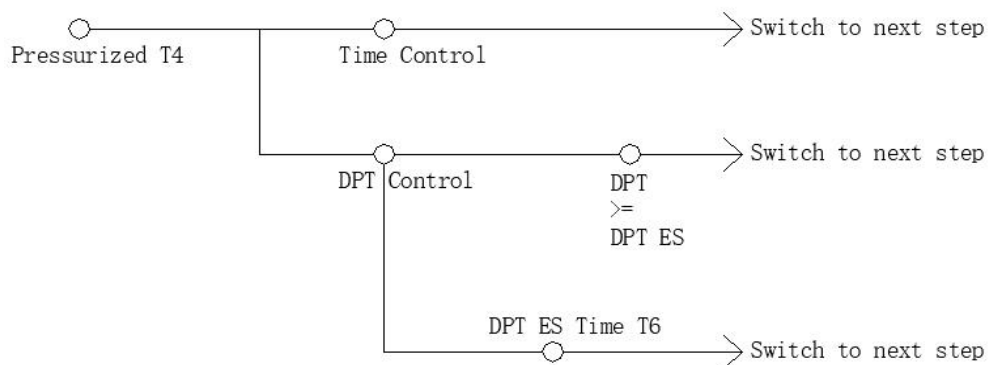

## 六、Function parameter screen (permission required)

In the main screen, press [3], Switch this screen  
Function parameter 1:

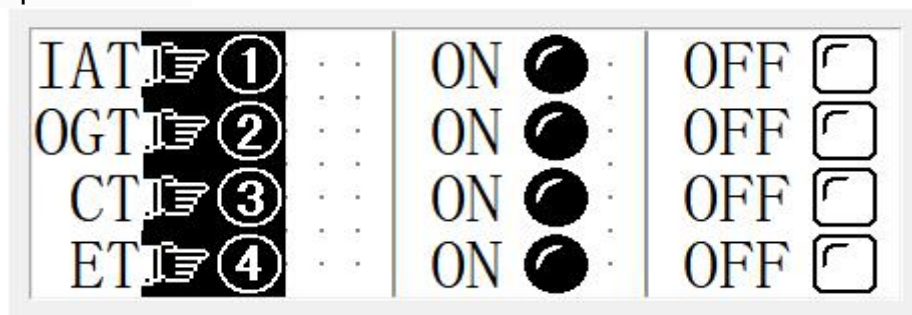

【1】 【2】 【3】 【4】	Function key (only this screen is valid)
-----------------	--

Function parameter 2:

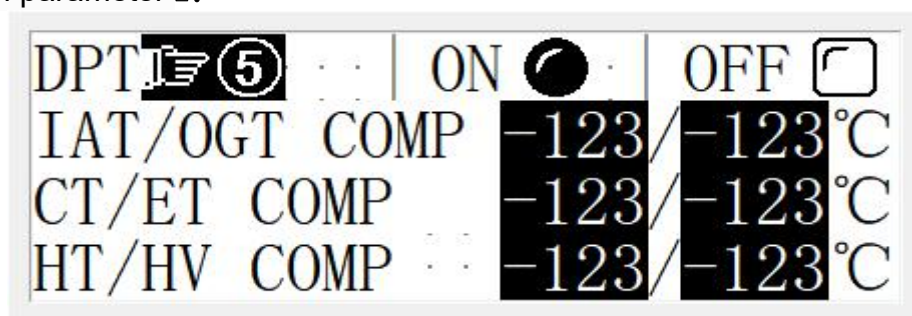

【5】	Function key (only this screen is valid)
-----	--

Function parameter 3:

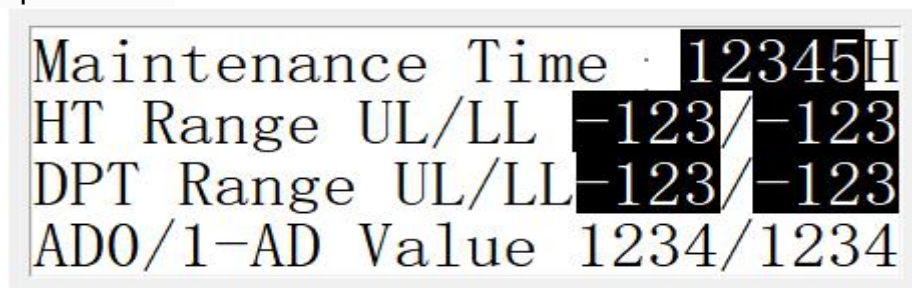

Function parameter 4:

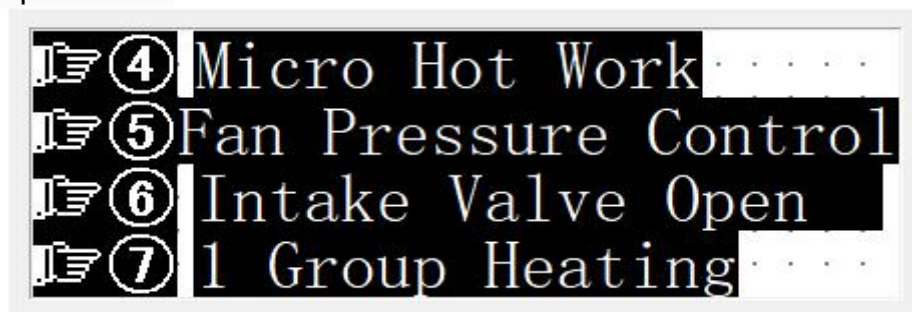

Key	Functions and permissions	purpose
Function key (only this screen is valid)		
【4】	Shortcut key (no permission)	Switching Micro Hot Work/No Hot Work
【5】	Shortcut key (no permission)	Fan Pressure Control: Fan pressure control switch

		Fan CT Control: Condensation temperature
【6】	Shortcut key (no permission)	Switching Intake Valve Open/Closed
【7】	Shortcut key (no permission)	Select 1 / 2 groups for heating

Function parameter 5:

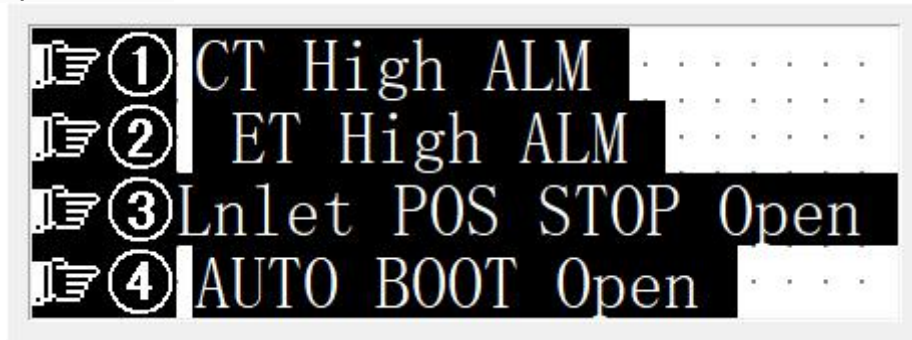

Key	Functions and permissions	purpose
Function key (only this screen is valid)		
【1】	Shortcut key (no permission)	CT High ALM: Temperature alarm only CT High STOP: Over temperature shutdown
【2】	Shortcut key (no permission)	ET/DPT1 High ALM: Temperature alarm only ET/DPT1 High STOP: Over temperature shutdown
【3】	Shortcut key (no permission)	Lnlet POS STOP Open : Air inlet pressure switch alarm shutdown Lnlet POS STOP Close: The air inlet pressure switch alarms and stops the heater only
【4】	Shortcut key (no permission)	AUTO BOOT Open : The system is powered on automatically AUTO BOOT Close: This function is off

Function parameter 6:

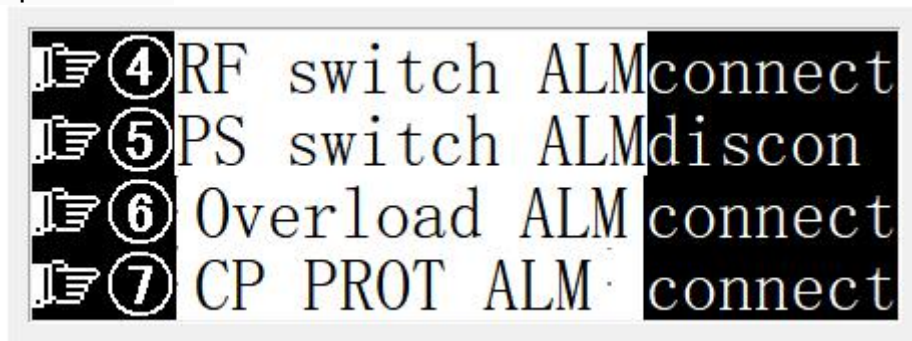

Key	Functions and permissions	purpose
Function key (only this screen is valid)		
【4】	RF switch ALM connect/discon	(Refrigerant high / low pressure switch) Connect: connect to normally open point discon: connected to normally closed point
【5】	PS switch ALM connect/discon	Connect: connect to normally open point discon: connected to normally closed point
【6】	Overload ALM connect/discon	Connect: connect to normally open point discon: connected to normally closed point
【7】	CP PROT ALM connect/discon	Connect: connect to normally open point discon: connected to normally closed point

Function parameter 7:

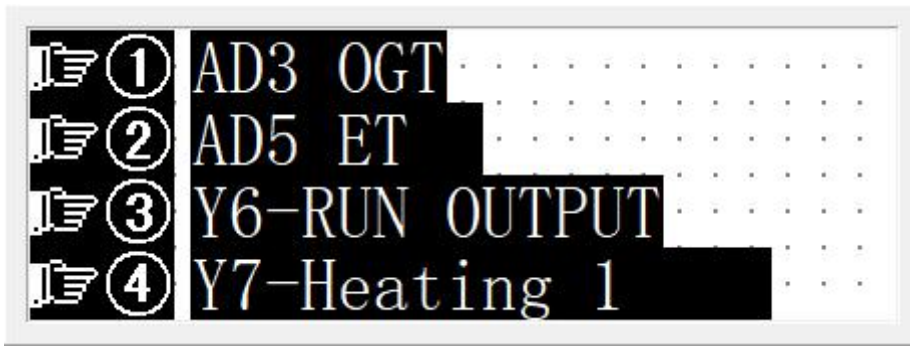

Key	Functions and permissions	purpose
Function key (only this screen is valid)		
【1】	Shortcut key (no permission)	Switch AD3 OGT/FT
【2】	Shortcut key (no permission)	Switch AD5 ET/DPT1
【3】	Shortcut key (no permission)	Switch Y6-RUN OUTPUT/Heating 2/Fan
【4】	Shortcut key (no permission)	Switch Y7-Heating 1/Remote Output/Spare Note: micro heat combination machine can only be used for heating 1

Function parameter 8:

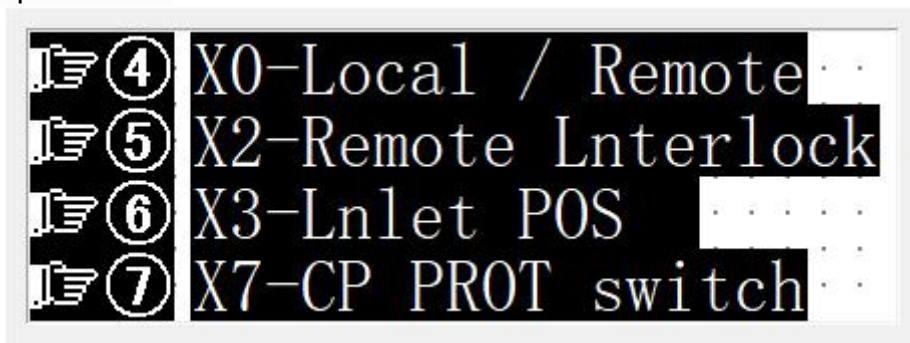

Key	Functions and permissions	purpose
Function key (only this screen is valid)		
【4】	Shortcut key (no permission)	Switch X0-Local / Remote;HT PROT switch select
【5】	Shortcut key (no permission)	Switch X2-Remote Lnterlock; Remote Boot select
【6】	Shortcut key (no permission)	Switch X3-Lnlet POS; Remote STOP select
【7】	Shortcut key (no permission)	Switch X7-CP PROT switch; Lnlet POS select

Function parameter 9:

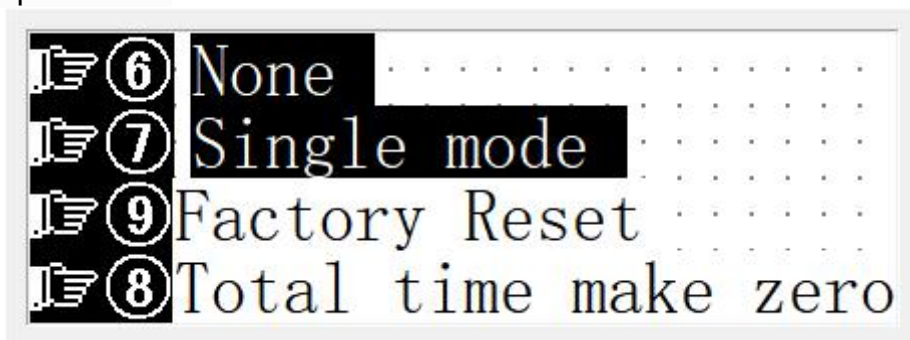

Key	Functions and permissions	purpose
Function key (only this screen is valid)		
【6】	Shortcut key (no permission)	Switch None/Odd/EVEN

【7】	Shortcut key (no permission)	Single mode : Local or remote start / stop only Dual mode: Local and remote power on / off at the same time
【8】	Shortcut key (no permission)	Factory Reset
【9】	Shortcut key (no permission)	Total time make zero

## 七: System working sequence diagram (Micro Hot Work)

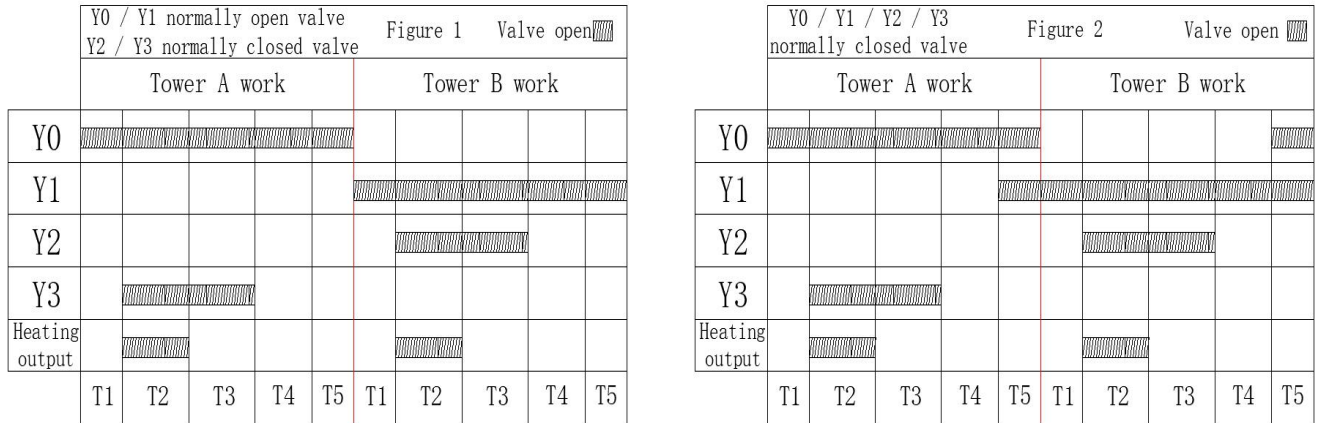

## 八: Password password



1. The password of the control box can't be changed at will. The default password is "---- 1234". If you need to change the password, please inform us in advance. We will change the password according to the customer's needs before the product leaves the factory.

2. Remember to turn off the password after each parameter modification to prevent others from modifying it wantonly. .

3. How to operate the password when modifying parameters:

1. PRESS "ENT" once
2. "1. Open password"
3. PRESS "ENT" again
4. Input the password according to the figure above, increase or decrease the number with the [↑] [↓] key, shift with the [←] [→] key, and then confirm with the ENT key

## 九、Alarm and reason

Serial number	Alarm display	reason	result
1	RF High pressure ALM (Manual reset)	Refrigerant high pressure switch on or off alarm	Shutdown
2	RF Low pressure ALM (Manual reset)	Refrigerant low pressure switch on or off alarm	
3	PS switch ALM (Manual reset)	Phase sequence switch on or off alarm	
4	Overload ALM (Manual reset)	Overload switch on or off alarm	
5	CP PROT ALM (Manual reset)	Compressor switch on or off alarm	
6	HT High ALM (Manual reset)	Alarm when the heating temperature is higher than the set value	
7	HT sensor fault (Automatic reset)	Heating sensor broken, damaged and temperature transmitter failure	
8	HT PROT switch ALM (Manual reset)	Heating protection switch on alarm	
9	HT Abnormal ALM (Manual reset)	When the heater is working, the heating temperature does not rise 5 °C in the "abnormal heating time" (compare within 50 °C) (shield at 0)	
10	Lnlet POS ALM (Manual reset)	Air inlet pressure control switch on alarm	Stop or no stop is optional (No downtime by default)
11	ET High ALM (Manual reset)	Alarm when the evaporation temperature is higher than the set value	
12	DPT1 High ALM (Manual reset)	Alarm when dew point 1 is higher than the set value	
13	CT High ALM (Manual reset)	Alarm when the condensation temperature is higher than the set value	
14	IAT High ALM (Automatic reset)	Alarm when the intake air temperature is higher than the set value	Non-stop
15	OGT High ALM (Automatic reset)	Alarm when the outlet temperature is higher than the set value	
16	FT High ALM (Automatic reset)	Alarm when the freezing temperature is higher than the set value	
17	CT sensor fault (Automatic reset)	Broken line, damage of condensing sensor and failure of temperature transmitter	
18	Maintenance Time ALM (Manual reset)	The running time is greater than the maintenance setting value (shield when 0)	
19	DPT High ALM (Automatic reset)	Alarm when the dew point temperature is higher than the set value	

## 十、Wiring diagram

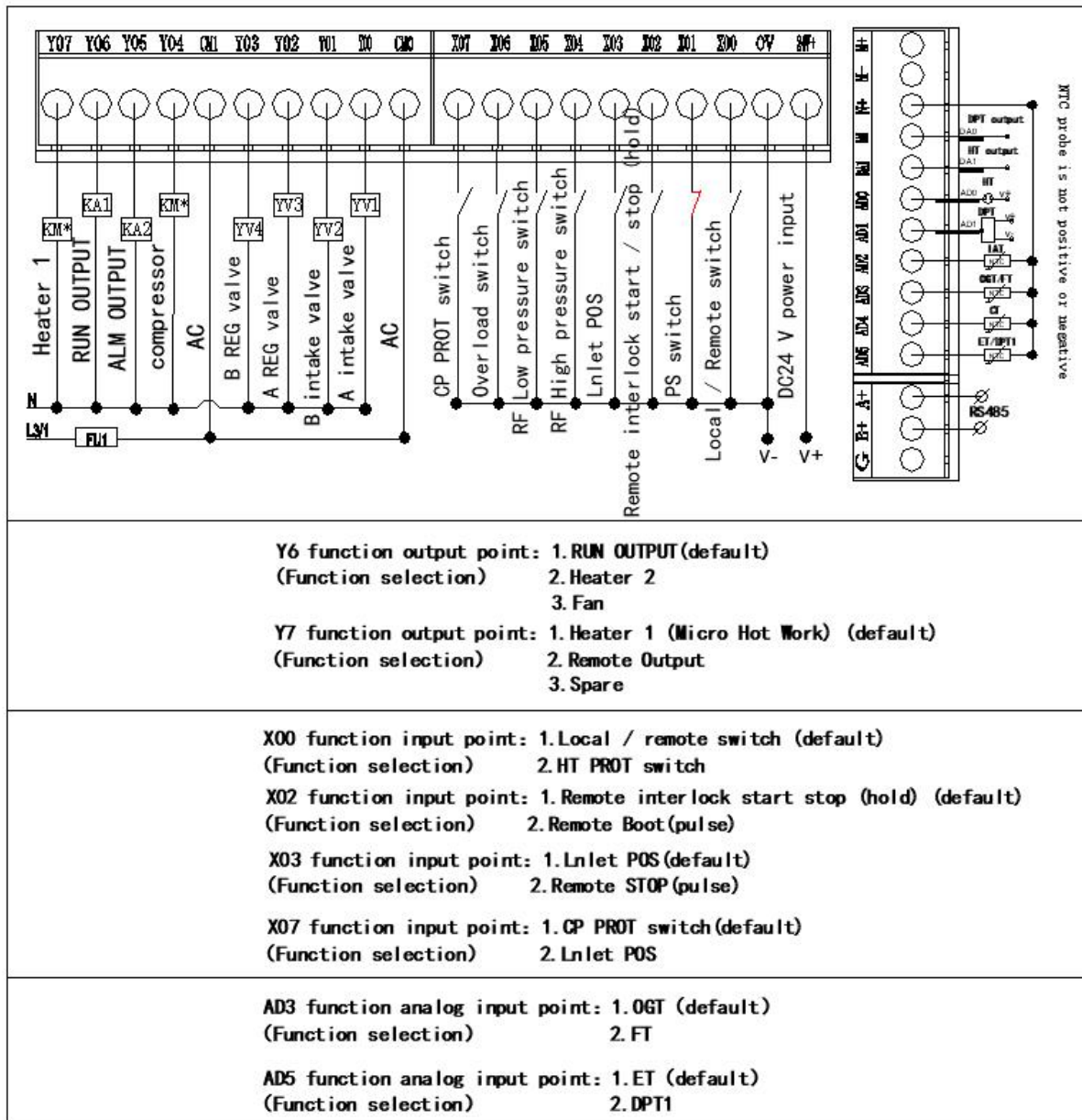

## 十一、Warranty Period

Under normal storage and transportation conditions and in good condition of product package or product itself, the warranty period of the product is 12 months from the date of sale. The following situations are not covered by the warranty:

- 1) Damage caused by improper use, storage and maintenance of users.
- 2) Damage not caused by the organization or personnel assigned by the company, or self disassembly and repair.
- 3) The product is beyond the warranty period.
- 4) Damage caused by force majeure.

## Chapter 3 Modbus Communication

### 一、Connecting PC and controller

#### 1. communication protocol

This machine adopts standard Modbus communication protocol, baud rate is 9600. The transmission mode adopts RTU mode, and the bits of each byte are: one start bit, eight data bits, one even check bit, one stop bit and CRC cycle detection.

The default slave address of the device is 2 (settable, but it is only effective after power on again), baud rate is 9600, check bit is even (settable)

2. Connector: 3=A, 8=B

### 二、Mailing address details:

1. The test is as follows: test software: MODSCAN32

Address:	<input type="text" value="0070"/>	Device Id:	<input type="text" value="2"/>	Number of Polls: 2676 Valid Slave Responses: 2676
Length:	<input type="text" value="30"/>	MODBUS Point Type	<input type="text" value="03: HOLDING REGISTER"/>	
				<input type="button" value="Reset Ctrs"/>

Configuration	
Baud	<input type="text" value="9600"/>
Word	<input type="text" value="8"/>
Parit	<input type="text" value="EVEN"/>
Stop	<input type="text" value="1"/>

40070:	< 0>	40082:	< 1>	40094:	< 0>
40071:	< 0>	40083:	< 8>	40095:	< -40>
40072:	< -75>	40084:	< 0>	40096:	< -1>
40073:	< 35>	40085:	< 18>	40097:	< -40>
40074:	< 28>	40086:	< 0>	40098:	< -1>
40075:	< 48>	40087:	< 0>	40099:	< 0>
40076:	< 17>	40088:	< 0>		
40077:	< 0>	40089:	< 0>		
40078:	< 0>	40090:	< 0>		
40079:	< 1>	40091:	< -7036>		
40080:	< 1>	40092:	< 0>		
40081:	< 0>	40093:	< -400>		

## 2.Address table

Serial number	Parameter name	PLC address	Modbus address	Reading /writing	unit	data type	state
<b>Zone 3</b>							
1	HT	D70	40071	Reading	°C	INT	
2	DPT	D71	40072	Reading	°C	INT	
3	IAT	D72	40073	Reading	°C	INT	
4	OGT/FT	D73	40074	Reading	°C	INT	
5	CT	D74	40075	Reading	°C	INT	
6	ET/DPT1	D75	40076	Reading	°C	INT	
7	Remote start / stop	D78	40079	Reading /writing		INT	=1Remote start =0Remote stop
8	Remote Runing signal	D79	40080	Reading		INT	=1Equipment Runing =0Equipment shutdown
9	Remote ALM signal	D80	40081	Reading		INT	=1 ALM =0 No ALM
10	Remote control signal	D81	40082	Reading		INT	=1 Remote control =0 Local control
11	Work phase countdown	D82	40083	Reading	S	INT	
12	Total Time	D83	40084	Reading	H	INT	
13	Working stage	D84	40085	Reading		INT	=0 Pressurized in =1 B Work A Delay REG =2 B Work A Heating =3 B Work A Blowing Cold =4 B Work A Pressurized =5 B Work A Work =6 A Work B Delay REG =7 A Work B Heating =8 A Work B Blowing Cold =9 A Work B Pressurized =10 A Work B Work =11 Readiness =12 Boot buffer delay =13 Cold dryer runing =14 Shutdown Delay =15 B Work A DPT ES =16 A Work B DPT ES =17 B Work A Once REG =18 B Work A Twice REG =19 A Work B Once REG =20 A Work B Twice REG
<b>Zone 0</b>							
14	A intake valve	Y0	00301	Reading		BOOL	1 = the solenoid valve has power; 0 = the solenoid valve has no power
15	B intake valve	Y1	00302	Reading		BOOL	
16	A regeneration valve	Y2	00303	Reading		BOOL	
17	B regeneration valve	Y3	00304	Reading		BOOL	
18	Compressor	Y4	00305	Reading		BOOL	1 = compressor has power; 0 = compressor has no power